

BASIC

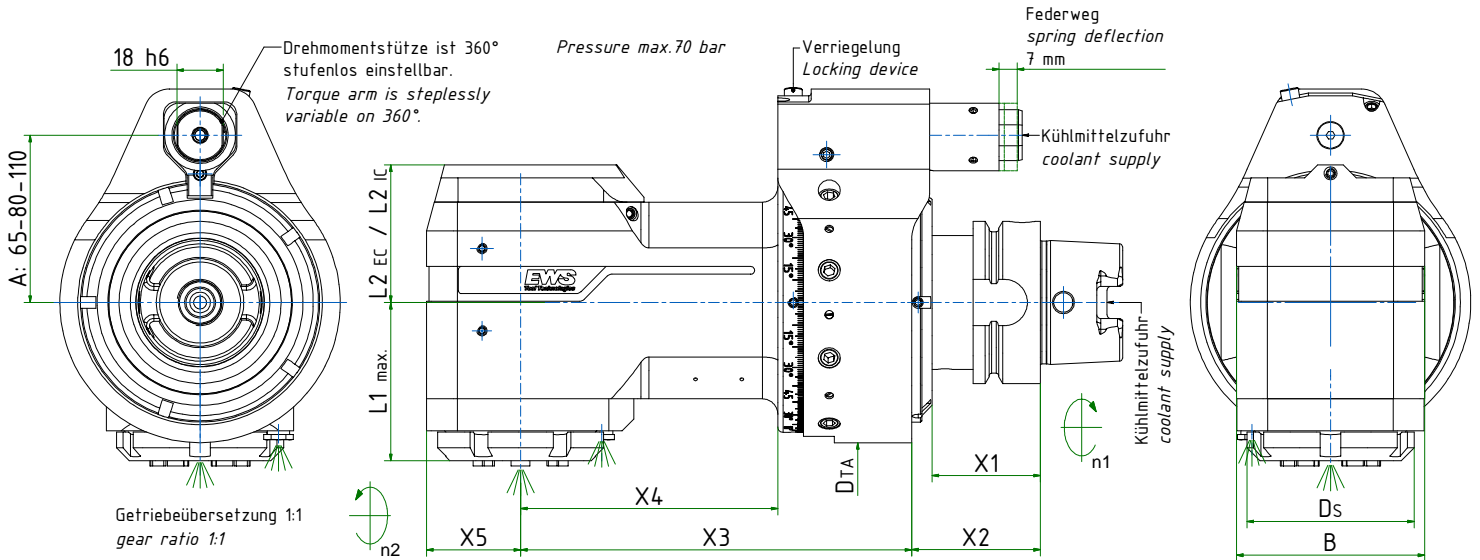

Coolant Type

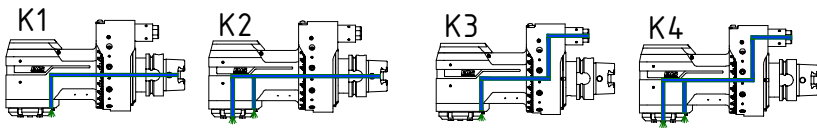

SHAFT	BT40	BT50	SK40	SK50	CAT 40	CAT 50	PSC 40	PSC 50	PSC 63	PSC 80	HSK40	HSK50	HSK63	HSK80	HSK100
X1	43	50	35	35	35	35	26	27	29	30	35	42	42	42	45
X2	51	58	43	43	43	43	34	35	37	38	43	50	50	50	53

SIZE	STD COLLET	T (Nm)	RPM	LENGTH	X3	X4	X5	L1	B	DS Ø	L2 EC (with ext. coolant)	L2 IC (with int. coolant)	DTA Ø	COOLANT TYPE	WEIGHT (kg)
1	ER20	15	10000	SHORT	97	51,5	24,0	43,5	48	46	35,1	42,0	85	K3 K4	4,2
1	ER20	15	10000	STANDARD	147	101,5	24,0	43,5	48	46	35,1	42,0	85	K1 K2 K3 K4	4,7
1	ER20	15	10000	LONG	177	131,5	24,0	43,5	48	46	35,1	42,0	85	K1 K2 K3 K4	4,8
2	ER25	30	8000	SHORT	90	38,0	26,0	56,9	54	52	37,0	44,0	98	K3 K4	4,9
2	ER25	30	8000	SHORT	113	61,0	26,0	56,9	54	52	37,0	44,0	98	K1 K2 K3 K4	5,2
2	ER25	30	8000	STANDARD	137	85,0	26,0	56,9	54	52	37,0	44,0	98	K1 K2 K3 K4	5,7
2	ER25	30	8000	LONG	197	145,0	26,0	56,9	54	52	37,0	44,0	98	K1 K2 K3 K4	6,3
5	ER32	70	6000	SHORT	107	55,0	36,5	62,6	73	65	48,5	53,5	109	K3 K4	6,5
5	ER32	70	6000	STANDARD	152	100,0	36,5	62,6	73	65	48,5	53,5	109	K1 K2 K3 K4	9,5
5	ER32	70	6000	LONG	217	165,0	36,5	62,6	73	65	48,5	53,5	109	K1 K2 K3 K4	10,5